



440 Rutherford St. P.O. Box 847 Goleta, CA 93117
1-888-888-4079 • FAX 805-692-2523 • www.supercharger.com

Installation Instructions

SUPERCHARGER

'01-'05 Mazda Miata 1.8L

01-03 ONLY CARB EO# D-453-5

999-280 w/ power steering, w/ AC

999-285 w/ power steering, w/ out AC

999-290 w/ out power steering, w/ AC

NOTE: Will not work with factory strut tower braces

INSTALLATION TIME IS AROUND 8-10 HOURS FOR MOST EXPERIENCED MECHANICS.

TOOLS REQUIRED: 3/8" Drive Socket set w/ 17mm, 14mm, 13mm, 12mm, 10mm, & 8mm sockets; Deep sockets (14mm or 9/16", 10mm); Phillips and Standard screwdriver; 10mm, 12mm, and 17mm open end wrench; 5mm Allen wrench with a 3/8" drive, a box to store your OLD PARTS in. A 1/4" drive socket set will be useful with some of the tight working areas.

A NOTE ON ADDING A SUPERCHARGER TO YOUR MIATA

This system has been carefully designed with attention to every detail utilizing over 1000 hours of engineering and testing. Each component of this system has been carefully designed to match the quality of the automobile you purchased from Mazda. The only added maintenance item for your Miata will be an occasional belt tension check for the supercharger drive. As for your engine's life, a Miata engine in good condition will see little reduction in useful life with the addition of this system. However, it is your responsibility to insure that your engine is in tiptop shape before you install this system. Putting boost on a tired engine will lead to catastrophe. If your car has under 100,000

miles on it and has had the oil changed regularly (every 3000 miles or so), you should have no trouble. Your cooling system should be up to par (new coolant). Basically, if you have a good engine, it will be very happy with this supercharger, as will you.

BEFORE INSTALLING THIS SYSTEM:

- A) Drive your fuel tank empty and refill with Premium Octane 91 or better major brand gasoline.
- B) Change your oil and filter. Use synthetic oil if possible.
- C) Change your spark plugs if they have more than 10,000 miles on them. We suggest a set of slightly cooler plugs Jackson Racing # 971-050. Use anti-seize compound on the threads.
- D) Change your fuel filter, if it has more than 20,000 miles on it. This is critical.

1.0 DISASSEMBLY

- 1.1 Disconnect your Miata's battery, making sure that you know your radio secret code if you have programmed it with such (if you haven't programmed it, don't worry, it won't lock up).

Figure 1.4

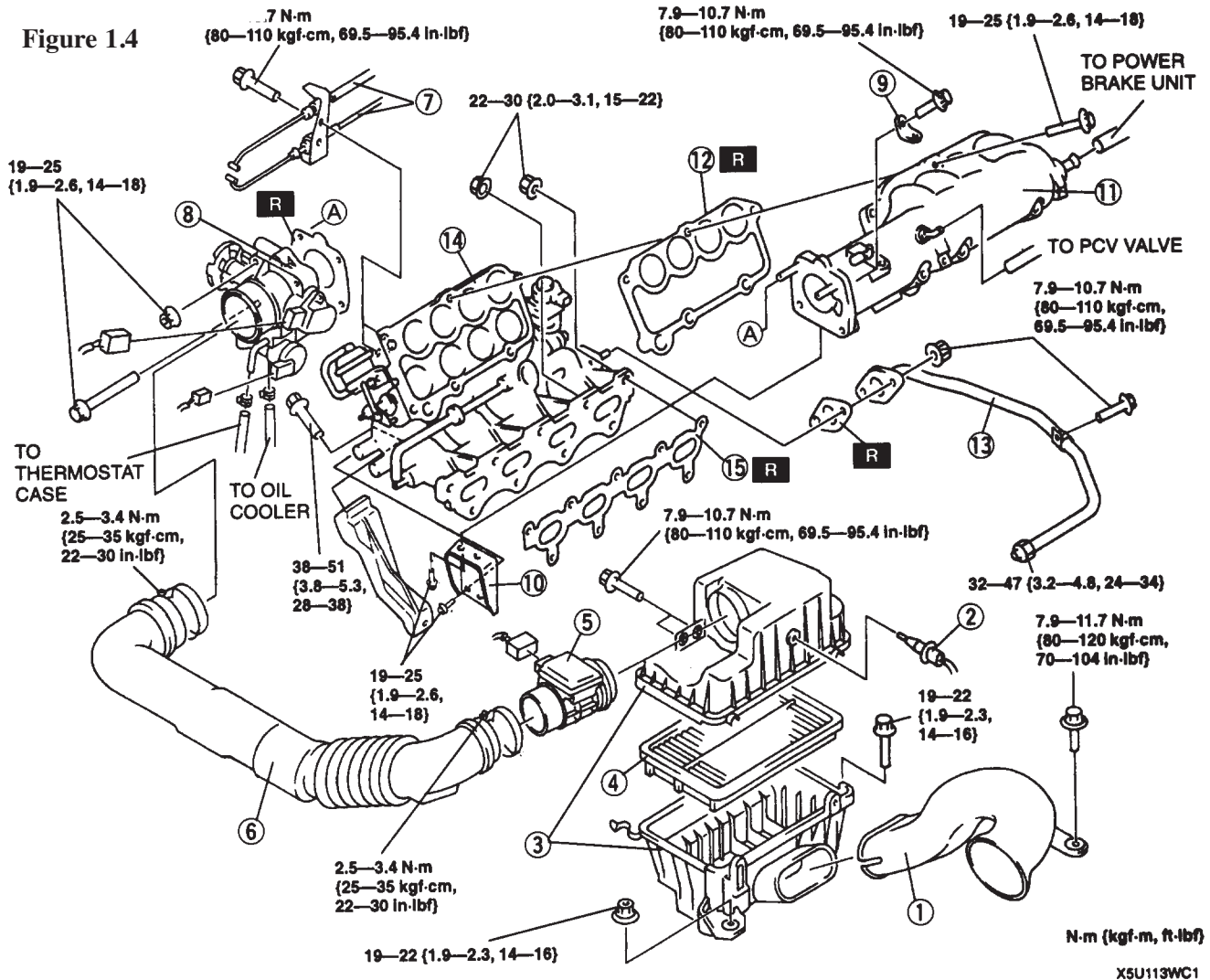

1.2 Release the air mass sensor harness connector by pressing the locking tab on its clip. #5 in above illustration. Remove the stock air mass sensor from the air box by removing the two 10mm headed retaining bolts and then remove the Air Temperature sensor with its rubber mounting grommet from the Air filter box. And finally remove the air filter assembly complete with intake snorkel, these parts will not be reused. Move the air mass sensor to a safe place on a worktable.

1.3 Remove the molded rubber elbow and hard plastic tube that lead from the throttle body to the airflow meter.

1.4 Remove the crankcase vent hose that is attached to the front of the cam cover. (Figure 1.4). This will not be reused.

1.5 You can do this entire procedure without losing too much coolant, there is no need to drain your cooling system. In the upcoming step you will be removing the throttle body and Idle Control Solenoid (ICS) valve. If you remove the small coolant hoses that run to the ICS

valve (which is mounted under your throttle), you can drain the excess coolant into a coffee can or such. Rest the can on the steering rack down in front of the engine and aim the hoses into the can as they drain. Once the flow stops, you can remove the throttle body without making a mess.

2.0 THROTTLE BODY

2.1 Remove the throttle body, #8 above (FIGURE 1.4) by releasing the two electrical connectors, the two small coolant hoses on either side of the lower Idle Control System (ICS) valve, and the three nuts and one bolt. TIP: THE SPRING HOSE CLAMPS FROM MAZDA ARE BEST REMOVED BY APPROACHING FROM THE SIDE WITH NEEDLE NOSE PLIERS. GRASP ALL THREE TANGS AT ONCE AND COMPRESS THEM TOGETHER. THIS IS EASIER TO DO WITH THE THROTTLE BODY ALREADY LOOSE FROM THE INTAKE MANIFOLD. Plug the coolant hoses with a screwdriver, golf tee, or pencil to prevent the leakage of coolant (OR - keep the hose ends above the radiator cap level to prevent leakage). Release the throttle cable from the throttle shaft pool..

If the throttle body gasket tears as you remove it (even though it is made of metal, it can tear), you will need to clean off the old gasket from both surfaces, the throttle body and the intake manifold. Carefully use a knife or the backside of a hacksaw blade to scrape the mounting surfaces clean. **DO NOT SCRATCH OR MAR THE MOUNTING SURFACES IN ANY WAY.** New paper style gaskets are supplied with the kit if the gasket gets torn. Immediately below, and behind, the throttle body on the intake manifold is a steel support brace in the shape of an inverted “L” attached by four 12mm headed bolts, #10 on opposite page. Remove the brace and re-secure the wiring harness ground wire attached at that point with one of the 12mm headed bolts.

2.2 Moving to a worktable, remove the idle air control (ICS) valve from the bottom of the throttle body by removing the two Phillips head screws. Use a good quality screwdriver and be careful not to strip the Phillips head screw. If you cannot loosen a screw with the screwdriver, use a small set of pliers from the side. Carefully separate the two units. New gaskets are supplied with your kit.

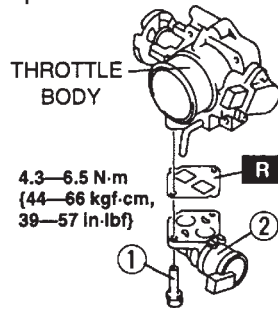

2.3 Take the Dummy Throttle body casting from your supercharger kit and install the Mazda Idle Air Control Valve (ICS) from step 2.2 on the bottom, rotating the ICS valve 180 degrees so that the electrical connector now points to the rear of the engine. Reuse the Mazda original ICS to Throttle body gasket or one of the new ones supplied with your kit.

2.4 Install the Dummy Throttle Body and ICS valve assembly back onto the intake manifold in the same position as the standard Mazda throttle body. Use the original gasket or one of the new ones supplied and the two original mounting bolts and two new 8mm x 40mm long bolts provided in the lower two holes on the dummy throttle body. Reconnect the coolant hoses to the brass coolant barbs on the front and side of the dummy throttle body.

2.5 Do not connect the ICS electrical connection until after the next step.

2.6 Wiring Harness Modifications:

Locate the main engine wiring harness on the left side of the engine (as viewed from the front of the engine) where it runs between the intake manifold and cam cover. Cut the strap of the white plastic harness anchor at the front and release the firewall end of the harness

by gently prying the release tab on the securing clamp located near the rear engine lifting eye. Starting at the forward point where the four black/yellow wires come out of the harness, cut the black tape binding the plastic corrugated tubing so that you can access the wires within. Locate the wiring branch of the ICS valve connector and follow the wires to the main harness. Pull these two wires (purple and orange) back free from the main harness about 4-5 inches so that you have enough slack to plug the connector in the repositioned ICS valve. Cut a length of the small diameter corrugated tubing supplied in the kit to cover the wires on the ICS branch from the plug to the main harness with an additional inch of tubing to protrude into the main harness tubing. Locate the wiring harness branch for the Throttle Position Switch (TPS) that originally connected at the throttle body connector. Pull these wires back to about 4 inches from the firewall. If the construction of your particular harness is such that you cannot free all three wires (light green/red, green/black and black/pink) all the way back, cut the offending wire (usually light green/red) and pull the wires with the connector back free. Then strip about 1/4 inch of insulation off each end of the cut wire and using the Crimp connector supplied; insert a stripped end into each end of the connector. Crimp (collapse) each end of the connector onto stripped ends, making sure that the connection is secure. With the crimp connector installed on the wire, shrink seal the ends of the Crimp connector by heating it with a heat gun or a hair blow dryer. Using some of the small diameter corrugated tubing provided, cover the TPS harness branch. Wrap the main harness and branches with the roll of tape supplied in the kit, in the same manner as the factory had. Reattach the harness at the rear harness clamp by snapping it back in place and at the front by using a new Ty-Wrap strap through the base of the white plastic anchor. You can now plug in the ICS valve connector by routing the harness branch under and around the intake manifold to the ICS valve. The TPS connector will be plugged in after installation of the supercharger and throttle body assembly.

2.7 Locate the ICS blanking plate and take it over to your Mazda throttle body. Use the new gasket provided between the blanking plate and the Mazda throttle body. Install the blanking plate onto your Mazda throttle body using the two new Phillips head screws supplied in the kit. Insert the shaft of a Phillips or cross head screwdriver into the ends of the coolant connections. Gently twist the connections 90 degrees counter clockwise to their standard position so that they point in the same direction as the throttle body inlet. Do not worry if you kink the coolant connections, you are only

moving them out of the way and they will not be reused.

3.0 BELT DRIVES

3.1 NOTE: CARS WITH POWER STEERING: You will be re-arranging your power steering bracket components. Referring to figure 3.1, remove the slot bracket and pillow block by removing bolts "A", "C", and "D". Spin the power steering pump pulley until the nut on the main pump mounting bolt is visible, "B" in illustration. Insert a socket wrench (deep 14mm) here and hold the rear hex head with a 14mm box wrench.

Figure 3.1

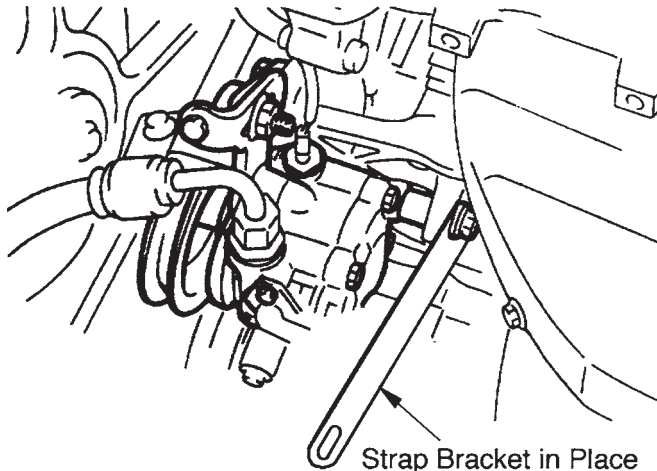
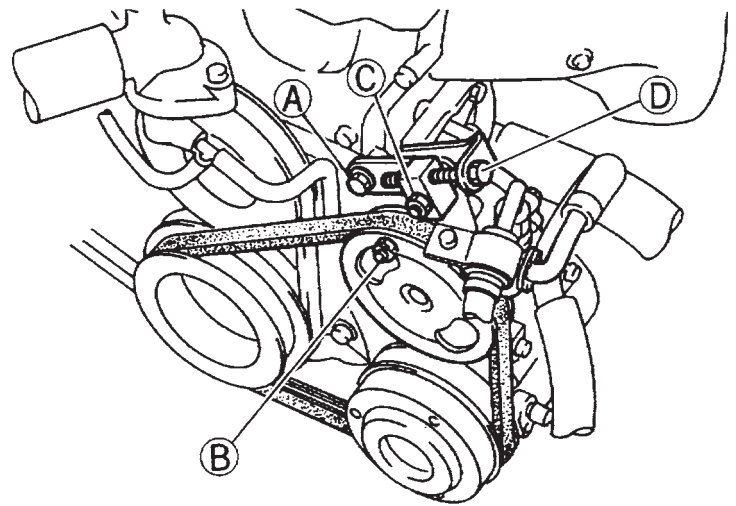

3.2 Pick the strap bracket from the kit and slip the non-slotted end over the power steering bolt. Reinstall the power steering pump nut with the flat bracket pinched between the nut and the cast power steering pump bracket that is on the engine.

3.3 NON-POWER STEERING CARS: Locate your lower bracket assembly from the kit. The end with the small 90 degree bracket mounts to the idler bracket (standard on AC equipped cars) or to new idler bracket (supplied with kit for non-AC, non-PS cars). Use the new, longer 10mm bolt provided to attach this bracket to the engine (Review figure 3.4 for bolt location).

3.4 Remove the power steering hose support bracket clamp from the support bracket. Rotate the power steering pulley until the slots are in a 12 o'clock and 6 o'clock position. Remove the two 14mm hex bolts that hold the original power steering hose support bracket and remove this bracket. It will be replaced in the next section with a new bracket. You now have room for the new power steering hose support bracket and belt tensioner bracket. The new belt tensioner bracket will be mounted over the stamped steel power steering hose bracket. Now rotate the power steering pulley to a 9 o'clock/3 o'clock position. Remove the lower power steering pump bolt.

3.5 With the power steering pulley back in the 12 o'clock/6 o'clock position, install the new power steering hose support bracket on the power steering pump using the lower bolt only at this point. The upper bolt is shared by the belt tensioner bracket. Refer to the illustration for mounting the belt tensioner bracket as it relates to power steering hose support bracket. See illustration below. Reinstall the upper power steering support bracket bolt through the belt tensioner bracket and into the power steering pump. Rotate the power steering pulley to the 9 o'clock/3 o'clock position. Reinstall the original power steering pump mounting bolt. The last remaining belt tensioner bracket mounting hole requires a special 14mm hex bolt with the top of the hex machined down to clear the idler pulley.



Install this bolt now and torque all belt drive/power steering support brackets at this time.



3.6 Secure the idler pulley closest to the engine firmly to the flat bracket using one spacer behind and one flat washer in front of the pulley. Proceed to install the other idler pulley and "T" nut assembly onto the idler bracket by installing the "T" nut from behind and thread the new idler with spacer into the "T" nut. Reinstall the power steering hose brackets around the power steering hose and tighten down to the new support bracket.

VERY IMPORTANT:

Check the clearance between the small coolant hose that runs from the base of the thermostat housing and the passenger side idler pulley. If the clearance is close between the hose and the pulley, trim three quarters of an inch of length off of the thermostat end of the small hose. Reinstall the hose, reusing the spring clamp. By removing a small piece of the hose end, the hose will be pulled away from the idler pulley, avoiding any damage during operation. This is a critical area for attention since a hose failure could cause severe engine damage. Not all cars need this modification.

4.0 FUEL MANAGEMENT

4.1 From the kit, locate Jackson Racing "PowerCard" Digital Fuel Management Module (DFMM), it will appear as a small black plastic box with 6 wires coming out of it. Using Velcro provided, you will be attaching the Jackson Racing PowerCard to the side of the factory Engine Computer Unit (ECU). The ECU is located directly above the brake/clutch pedals.

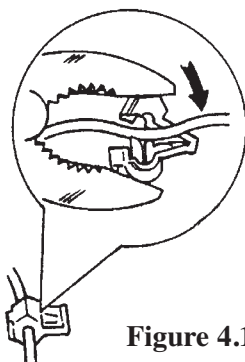

Figure 4.1

4.2 Locate the plug closest to the clutch/brake pedal. It will be a 17 pin connector. The top row of wires will be the injector wires. They are color coded in order from 999-280

the front corner, Yellow/Black, Purple/Blue, Yellow/Red, and Yellow/Green. Clamp a "T" Tap onto each of these wires. Plug the three gray wires and the one blue wire into these "T" Taps in any order. The sophisticated electronics of the Jackson Racing PowerCard establishes which injector is which and applies the correct duty cycle on its own.

4.3 Locate the plug furthest from the clutch/brake pedals. It will be a 31 pin connector. On the very top row of each end you will find a Blue/black wire and a White/Red wire. Clamp a "T" Tap onto each of these two wires. Plug the red wire from the Jackson Racing PowerCard into the White/Red wire. This will be your system 12v power. Plug the black wire from your Jackson Racing PowerCard into the Blue/Black wire. This will be your system ground.

4.4 You will need to route a hard plastic pipe from the intake manifold to the Jackson Racing PowerCard in the interior. To route the hard plastic vacuum pipe to the engine compartment, you will need a long narrow rod or screwdriver shaft approximately 24+” long. On the driver side of the engine compartment you will find a rubber grommet where the main wiring harness goes through the firewall. From inside the engine compartment, carefully push your long tool through the grommet.



met. Have someone watch from the interior so that you don't drive the tool through any vital parts other than insulation. Once through, you can tape the hard plastic vacuum pipe to the tool and carefully pull it back through the firewall. You should end up with a good weather tight seal and your vacuum pipe tucked cleanly away under the dash.

4.5. Route the hard plastic pipe across the back of the engine and across the valve cover. Connect this hard plastic pipe to the vacuum fitting on the intake manifold



(Fig. 5.3) prior to installing the supercharger. Make sure to install the 2.50" to 2.750" reducer hose to the airflow meter end of this elbow prior to setting it in place. This will greatly assist in air mass sensor installation. Also, install the 2.50" diameter hump hose to the throttle body end of this plastic elbow. Use the clamps provided to secure the hoses to the elbow.

with the small, 90-degree adapter hose. Connect the other end to the Jackson Racing PowerCard by sliding the hard plastic pipe into the silicone hose of the PowerCard.

4.6. Using the "Hook and Loop" material supplied with the kit, attach the PowerCard to the side of the ECU once the vacuum hose is connected.

5.0 SUPERCHARGER PREPARATION

5.1 Working on a table or bench, set the supercharger in a position easy to work with. Be careful not to bump the supercharger pulley in any way as it can easily damage the front bearing. Install your Mazda throttle body with the ICS blanking plate as installed in step #2.7 and mount it to the supercharger using the new gasket and the two new 8mm x 35mm long bolts supplied in the kit.

5.2 Locate your throttle cable bracket that is bolted to your standard intake manifold and remove the throttle cable by loosening the pinch nuts surrounding the cable end on either side of the bracket. Once the nuts are loose, you can pull the cable out of the bracket - the grommet will deform and let you do this. Remove the throttle cable bracket by removing the two 10mm headed bolts. Unclip the throttle cable from the firewall anchors. Begin re-routing the throttle cable by looping the end behind the brake master cylinder and laying its length along the driver's side fender well.

5.3 Locate the black plastic Roto-mold elbow from your kit. Check inside the elbow for any debris and clean it out if necessary. You will be placing the assembly into the position shown

6.0 SUPERCHARGER INSTALLATION

6.1 Remove the engine lift eyelet at the front of the engine, just above the exhaust manifold by removing the bolt using a 14mm socket. Install the new flanged headed bolt supplied with your kit into the boss on the side of your cylinder head. This is a special 14mm hex bolt with the top machined off of it to allow room for adjusting the supercharger forward and aft on the head after installation. Leave at least 1/2" of thread exposed on the bolt. Remove the heat shield from the exhaust manifold. Make sure to spray the small bolts with WD 40 or such and let them soak for a bit to make sure that they do not shear off during removal. Spray your exhaust manifold nuts with WD 40 or equivalent and let soak for ten minutes, reapplying at the five minute point. Remove the nuts from the two top center exhaust manifold studs (#2 and #3, counting from the front). Install the exhaust manifold to supercharger bracket over the two exposed studs. The third hole on the bracket should be offset upwards and away from the engine. Reinstall and tighten the two nuts. Remove the counter sunk bolt and nut which hold the main supercharger bracket to the small L-bracket attached to the supercharger unit. Discard the nut, it is for shipping purposes only. Locate the jam nut from the appropriate hardware bag (self locking prevailing torque nut: M10).

6.2 Bring the supercharger over to the engine. Feed the throttle body end into the hump hose already installed on the plastic Air mass sensor to throttle body elbow (make sure to slip a fully opened hose clamp over the hose first). Orient the supercharger so that

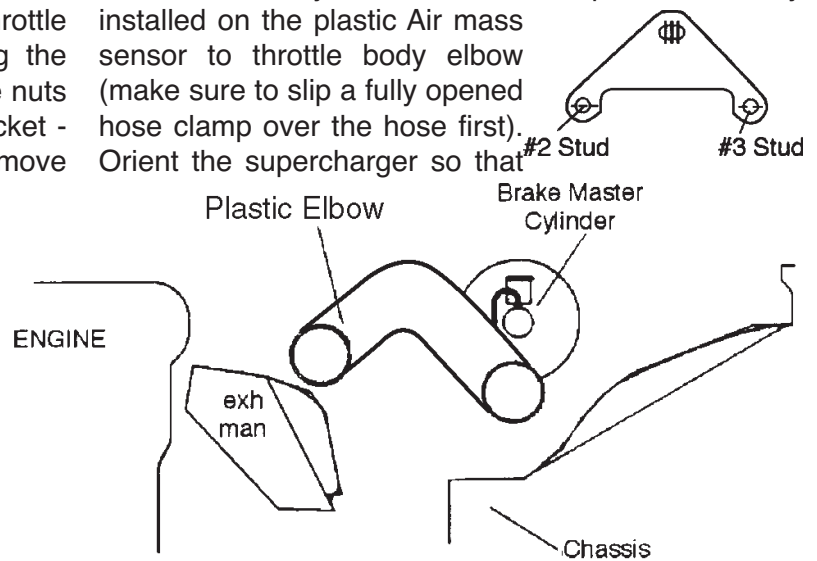

you can slip the forward large “keyhole” in the bracket attached to the supercharger over the bolt head installed in step #6.1. Make sure that the bolt moves up the respective vertical slot and seats against the upper edge of the horizontal slot in the bracket. Slide the supercharger towards the firewall as far as it will go. Reinsert the countersunk bolt removed earlier through the L-bracket, through the main S/C bracket, and through the hole in the exhaust manifold to S/C bracket. The jam nut that goes on this bolt fits tightly between the rear support bracket and the engine’s cam cover. Use an open-end wrench and some masking tape to hold the nut to the wrench while you feed it into place. Start the countersunk-head bolt with your other hand and run the pair down tight. Tighten down the front pinch bolt using an open-end wrench. If you find that the bracket/supercharger assembly collides with your cam cover vent tube during initial installation, it means you did not leave enough threads exposed on the main mounting bolt installed in step #6.1. Retry it with the bolt further out.

6.3 Swing the flat lower bracket up into place in front of the supercharger boss. Locate the small stamped throttle cable bracket from your kit and thread the new bolt through the throttle cable bracket hole, through the spacer, through the supercharger boss and through the flat steel lower bracket. Secure with the locking nut and bolt supplied. Make sure that the head of the bolt

is on the throttle bracket side of the assembly.

6.4 Route your throttle cable so that it is looped back toward the firewall, routing the cable just behind the driver’s side headlamp. Install the cable’s threaded end into the small bracket attached to the underside of the supercharger. Make certain that the cable/grommet is fully nested within the slot (this may require some muscle – we made it tight so your throttle cable won’t ever fall out). Open the throttle by hand and insert the cable end into the throttle spool. Make sure that the cable runs in the center of the groove of the throttle spool. If it does not, adjust the throttle cable bracket left or right until it is centered in the spool’s groove. Have an assistant operate the gas pedal multiple times to confirm that the action is free and easy without binding or interference. Make sure that the cable has a bit of “sloppy” slack with the gas pedal released and that full throttle is available when the gas pedal is fully depressed. If it does not “flop” in the idle position, you will have trouble setting your idle speed. Make sure that the cable is run in such a way as to allow for engine movement from side to side. **Make very certain that all throttle cable mounting points are secure - this installation area is critical for safe operation of your car. This bracketry has been carefully designed for correct operation. It is your responsibility as the installer to insure that it is bolted together suc-**

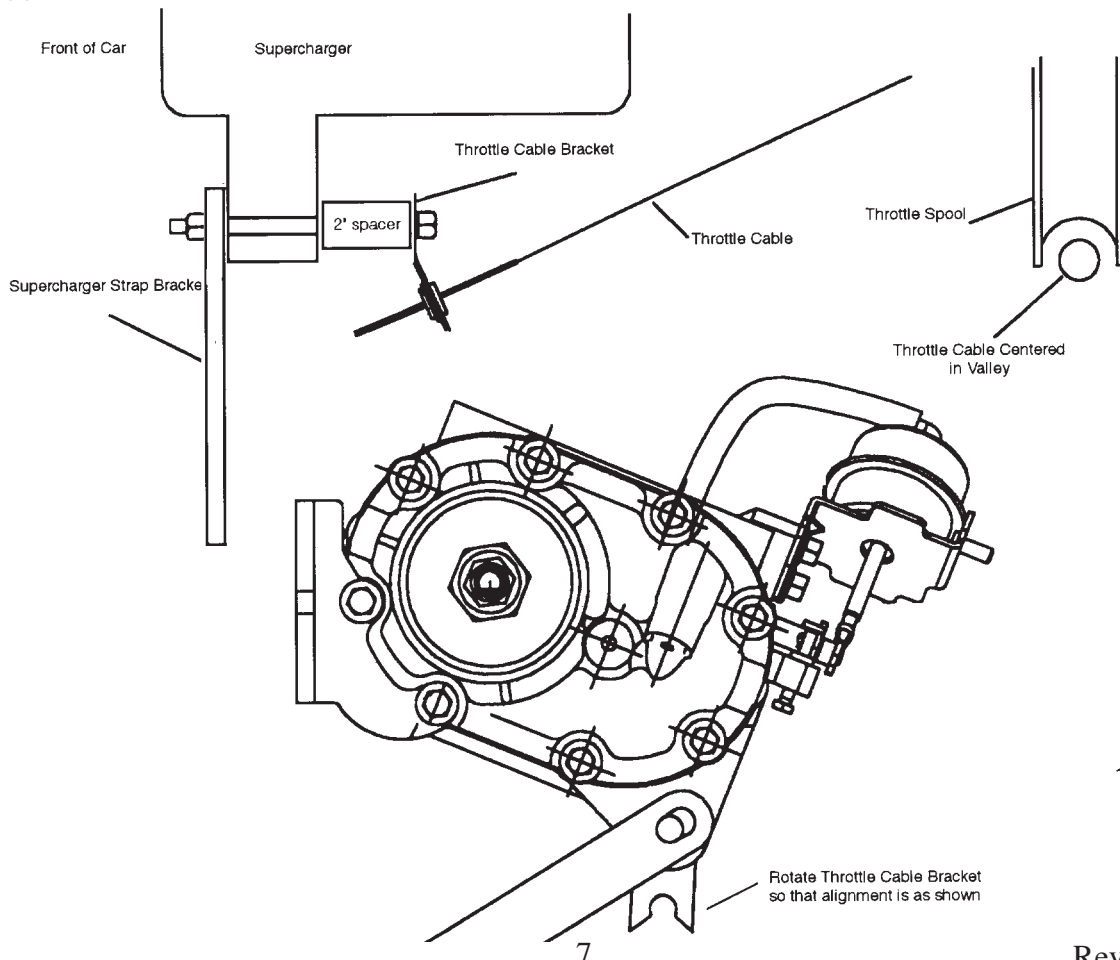

cessfully without binding or interference.

7.0 AIRMASS SENSOR WORK

7.1 Locate the new air filter base from your kit and install it to the airmass sensor intake port using the reducer hose and clamps. Note the "Arrow" cast into the side of the airmass sensor, it denotes the direction of airflow through the meter. It should point away from the air filter base, towards the firewall of the car. The correct orientation of the airmass sensor will be such that the electrical plug connection will be facing the LEFT side near the bottom, when looking in the inlet port of the air filter base.

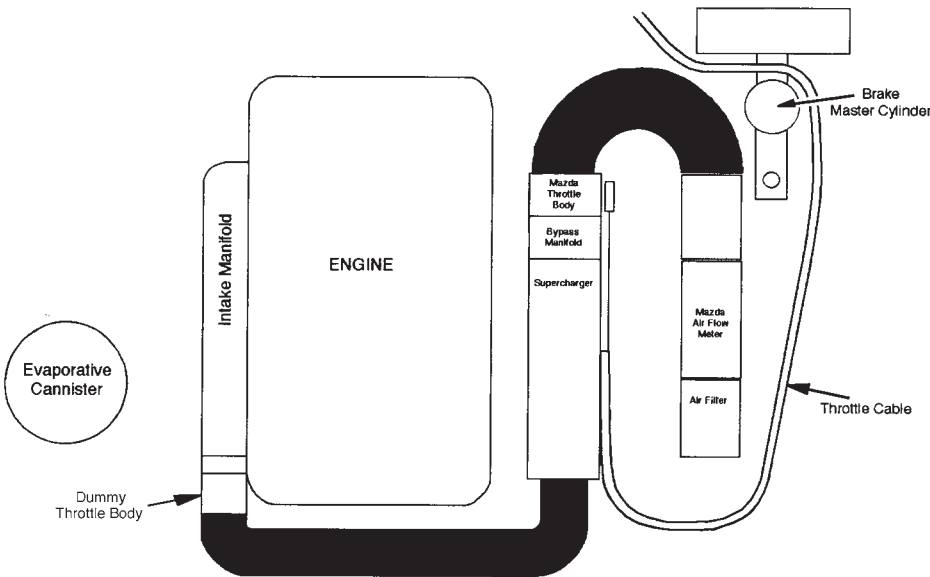

7.2 Locate the driver's side shock tower support and notice the Mazda air filter box mounting bracket (painted body color) on the forward edge. This vertical bracket is held in place by a horizontal bolt (also painted body color). Remove the bolt using a 10mm socket and store the bracket.

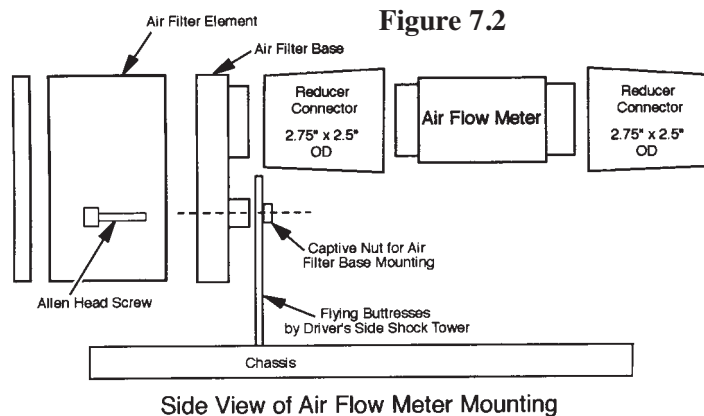

7.3 Bring the airmass sensor with the air filter base installed over to the engine bay. Tilting the assembly at an angle, feed the airmass sensor outlet into the rubber reducer sleeve already in place on the plastic elbow (install loose hose clamp first). The airmass sensor assembly fits into the space just inside the shock tower. Install the rubber grommet that you earlier removed from the stock Mazda air filter box into the 3/4" hole in the base of the new Air Filter. Insert the grommet from the backside so that the grommet's flange is on the outside of the filter base. The small hole and boss in the air filter base will line up with the horizontal hole you just removed the 6mm body colored bolt from. Using the longer bolt provided (M6 x 30mm, Allen head), attach the air filter base/air flow meter assembly to the car using this bolt (it mounts horizontally, through the air filter base, the flying buttress, and into the Mazda captive nut on the flying buttress). Use thread-locking compound. Make sure that the electrical connector on the air flow meter is still accessible for the main wiring harness connector to be installed.

7.4 Make sure that there is no chaffing or rubbing anywhere along the plastic elbow assembly, even though it is a very tight fit. Gently reposition any brake lines that are pressing against the elbow. Make sure all joints and clamps are secure - a leak in this area will keep your car from idling correctly. However, never over tighten your clamps, they may break somewhere down the road.

7.5 Locate the 2 pieces of 10mm silicone hose. They will measure 18" and 14". Locate the 90 degree plastic vacuum fitting, and 3/8" x 1/4"NPT hose barb. These are all supplied in the kit. Thread the hose barb into the plastic inlet elbow. It will only go in one hole. Then attach one end of the 18" piece of hose to the fitting. Run the hose along side the valve cover toward the front of the engine. At the front of the motor insert the 90 degree fitting then connect one end of the 14" hose to the elbow. Attach the other end to the brass elbow on the Dummy Throttle Body. Secure the 14" hose near the 90 degree fitting to the main wiring harness running across the front of the motor using a zip tie. Be careful not to pinch the hose or idle will be affected.

7.6 Install the air filter element over the air filter base. Install the waffle patterned air filter cap and secure

using the nuts provided. Use the Ty-Wrapps provided to secure all components and keep them clear from



the belt runs, exhaust manifolds and throttle cables.

7.7 Take the throttle body wiring harness as left in step #2.6 and route the harness along the back of the engine. Route the branch of the harness, which has the Airmass Sensor and Air Temp Sensor connectors, along the front of the engine and under the supercharger, so that you can plug in these connectors. Tie-wrap the harness in at least two places. Connect the plug to the throttle position sensor and push the Air Temperature sensor into the grommet in the back of the air cleaner base.

7.8 Find the internal restrictor in the hose bag. Locate the 3/8" internal diameter hose from your kit and press the restrictor into this hose at least one inch. Attach this hose from the remaining fitting on the plastic elbow. Cut to length and attach the other end to the camshaft cover fitting on the exhaust side. Make sure the hose does not kink at any point and that the restrictor is not left out. If you leave the small restrictor out, the engine will not idle correctly.

7.9 Reconnect the electrical connector to the airmass sensor. Make sure the harness is not pinched at any point.

Belt Drive

UNDER NO CIRCUMSTANCES SHOULD YOU USE THE ENGINE STARTER TO "BUMP" THE BELT ONTO THE SUPERCHARGER. DOING SO PUTS A HIGH LOAD ON THE SUPERCHARGER BEARING AND WILL VOID YOUR WARRANTY. IT ALSO IS VERY DANGEROUS.

8.1 Install the new 4-rib drive belt. This new belt will run counter-clockwise from the crankshaft, around the air conditioning compressor, up to the power steering pump, over to the right idler pulley, up and over the supercharger pulley, just under the left idler pulley, and back down to the crankshaft.

NOTE: **Cars without air conditioning** - your belt run will be similar, but the belt will simply run from the crankshaft to the power steering pump. A shorter belt has been provided.

8.2 The idler closest to the engine should be tight at this point. Loosen the 17mm hex bolt slightly on the idler under the supercharger outlet manifold. Tighten the 10mm hex bolt under the supercharger outlet manifold until the proper belt tension is felt on the longest run of the supercharger belt. Tighten the 17mm idler pulley bolt once

the proper tension has been set. The longest run of the belt should not deflect more than 3/8 of an inch when pressed down with around 22 pounds of thumb pressure. The tension specification is 90 pounds. An easy check for proper belt tension is done by listening to your belts during warm up. If turning the steering wheel with the air conditioning on creates a squeal, then the tension is far too loose. In general, only a slight amount of black dust should appear around the supercharger nose when the tension is correct after a week of driving. Heavy dusting indicates excessive belt wear from a loose belt. Check your tension again after the first 500 miles - it will loosen slightly as the belt wears in. **NEVER ATTEMPT TO ADJUST THE BELT WITH THE ENGINE RUNNING!** Re-tighten all bolts and double-check your work.

INSTRUCTIONS FOR NON-POWER STEERING MIATAS WITH AIR CONDITIONING

To install the supercharger belt drive in your particular situation, follow the instructions as outlined in the installation manual except for section 3.0 on Belt Drives. Since you do not have a power steering bracket to attach your lower bracket to, you will use special bracketry that we have included with your kit. Turn to figure 3.4 in the installation manual and find the note describing the bolt that will be used for the non-power steering car's lower strap bracket anchor. The Mazda idler pulley set-up for your 4-rib belt has a cast iron bracket that is bolted to the engine block. This bracket is held on by three large bolts. The lower bolt of the triangle pattern will be the one you attach our "L" bracket to. It is in the position noted in figure 3.4. This is where you will attach the small "L" brack-



over tube involves putting the 2.75" diameter rubber sleeve on the supercharger manifold and the 2.5" diameter sleeve on the cross over tube, and attach both with clamps. Then install the cross over tube, starting at the supercharger end first. Note that the cross over pipe goes over the radiator hose.

9.2 Once the cross over pipe is installed correctly, double-check all your hose and tube connections. There should be no loose ends or connections. Do not over-tighten any hose clamps, but ensure that they are snug. Double check your power steering belt and supercharger belt for correct tension.

9.3 You are now ready to start your engine.

9.4 CLEARANCES

IMPORTANT!

MAKE SURE THAT YOU HAVE AT LEAST 3/4" INCH CLEARANCE BETWEEN ANY ENGINE MOUNTED COMPONENT AND ANY BODY MOUNTED COMPONENT.

CRITICAL AREAS:

- BYPASS ACTUATOR TO BRAKE LINES (VERY CRITICAL - The engine "rocks" strongly to the driver's side upon deceleration. If clearance is too tight, your brake lines can be gently deformed away from the supercharger bypass actuator by hand.)
- SUPERCHARGER OUTLET MANIFOLD TO AIR FILTER (INCLUDING CLAMPS)
- ALL VACUUM LINES TO THROTTLE SPOOL & CABLE

9.5 SUPERCHARGER BELT DRIVE ADJUSTMENT

Start your engine and observe your belt drive. The belt should line up with itself as it passes between the two idlers. To put it a different way, the portion of the belt running up to the supercharger should lay directly over the portion leaving the supercharger and heading toward the power steering pulley. If the upward run is more forward or rearward than the downward run, you need to move your supercharger slightly forward or backward with respect to the crankshaft pulley. Remember the two bolts attaching the superchargers bracket to the cylinder head from step 6.1? You can now access these two bolts with an open-end wrench. Loosen each bolt slightly to allow for adjustment. Start the engine. You can now move the supercharger assembly slightly forward or rearward to correctly align the drive pulleys. The slots in the supercharger mounting bracket will allow you to find the perfect alignment for the belt run.

NOTE: Do not attempt to move the supercharger with your hands with the engine running. Use an appropriate tool.

et to the engine block using the new M10x50 fine thread bolt we provide. The lower strap bracket can then be attached to this "L" bracket, supporting the outside of the supercharger. For the belt drive, please remove all the adjustment hardware from the cast iron Mazda idler bracket (the idler pulley, the special mounting bolt, the vertical adjustment bolt, etc.). You will be left with just the naked iron bracket on the engine. Using the 2.5" diameter idler we provide, and the M10x50 bolt, washer and nyloc nut, mount the nylon idler to the front of the Mazda cast iron bracket. Make sure to put the Mazda Cast Iron washer under the bolt's head and to aim the bolt toward the radiator (see diagram). Run the belt over the crank pulley the supercharger and around the air conditioning compressor. Push the idler downward and tighten its center bolt to properly tension the 4-rib belt. If you are careful, a screwdriver can be placed in the cast iron Bracket's vertical slot to lever the pulley downward. This will help you get the proper tension on the belt. You should have less than 3/8inch deflection on the longest run of the belt.

CROSS OVER MOUNTING

9.1 Locate the rubber sleeves and the front cross over pipe. Check inside the cross over pipe for debris and clean it out if necessary. Install the cross over tube between the idle air manifold (dummy throttle body now on the intake manifold) and the supercharger manifold. If you find the outlet rubber sleeves hard to slip over their respective landings, use some spray light oil such as WD40, which dries off, to lubricate the hoses. Do not use gasoline products or pure silicone products. The best technique for installing the cross

The best tool to use is a flat blade screwdriver placed between the forward bracket bolt and the front inside edge of the bracket. Move the supercharger assembly while watching the belt run across the idler pulley. If you have the two bracket bolts too loose, the supercharger will be out of alignment from side to side. Make sure the two bolts are snug enough to just allow some leveraged movement. Once you have the belt running true in the center of the idler pulleys, tighten the rear bolt to secure the position. Shut off the engine and tighten the other bracket bolt securely. Recheck all mounting bolts for tightness.

9.6. For trouble shooting and testing prior to driving your newly supercharged Miata follow these procedures. Unscrew the back of the "Jackson Racing PowerCard" box. You will see 3 LED lights in a row. The Yellow, Red and Green lights are fuel enrichment lights and MIL (Malfunction Indicator Lights) lights. Read the lights and refer to the following table to find the source of the MIL problem.

If the box has been wired for power and ground correctly you will see the Green light is illuminated and flashing with the ignition switch in the "On" position and the engine off. Start the car and check that the Green light is illuminated continuously and not flashing. There should be no other lights illuminated. If you have no lights when you power up the vehicle, you either have a power (Red wire) or ground (Black wire) problem. Double-check your connections at these two wires until they test properly.

If the Green light is flashing after the vehicle is started, the Blue wire is not connected to an injector wire or the connection is not complete. If the yellow light is flashing one of the Gray wires has a bad connection or is not connected to an injector wire. The Yellow MIL light will not function if the Green light is also flashing. In this case you must fix the Blue wire problem first.

Inside the box is one more LED located away from the other three LED's. This is your "Boost Activation" LED. Once the engine is warmed up, push the throttle hard so that the engine gains RPM quickly (creates Boost) and then let it come back to idle. During this process this LED should become illuminated temporarily. It only comes on when the Pressure Transducer in the box reads boost from the engine.

9.7 IDLE ADJUSTMENT:

Restart your engine. Using the idle air screw on your throttle body (now on the back of the supercharger),

adjust your idle speed to 950 rpm after the engine is warm. This is done by backing the adjustment screw out a half turn at a time until the correct speed is achieved (counter-clockwise rotation increases idle speed). Next, turn your headlights on BRIGHT and put your heater fan on HIGH. Leave the air conditioning off. Rev the engine briskly in neutral to at least 2500 rpm and release. Notice if the idle stops at 900 rpm. If it dips below this level and feels like it will stall, then recovers to 950 rpm, open the idle airscrew (counter-clockwise rotation) one tenth of a turn at a time until most of this "droop" disappears. A slight droop of 100 rpm or so is acceptable and normal. More than that may create a stalling problem during driving. Turn off the lights and heater fan and double check that your idle speed is 950 rpm.

FUEL QUALITY

It is recommended that unleaded gasoline of 91 octane rating or better should be required when your Miata is supercharged.

DRIVING TIP:

If you should find yourself in a situation where you cannot find high-octane fuel, you can bypass the supercharger temporarily. Note the position the bypass actuator arm is in during idle. This is the position that bypasses the boost air back into the supercharger inlet. As you blip the throttle, the actuator arm will move and close a butterfly valve inside the bypass manifold. Using a short piece of wire, fix the bypass actuator arm in the "bypass" position that it holds at idle. This will prevent boost from being developed and thus, detonation will not occur. Of course, your engine will now run like a stock Miata's, but will be quite operable for as long as you need. When you find higher-octane fuel, simply remove the wire to release the actuator arm and the bypass will function normally, closing during acceleration, bypassing during idle and cruise. Try to run the low octane fuel out of your tank before filling up. Mixing fuels of different octane will lower the overall rating and detonation could still be a problem.

Starting procedure: Start your engine as you would a standard Miata. Remember to bring the engine up to operating temperature (as indicated by your water temperature gauge) before running it hard. Full boost on a cold engine will greatly increase your engine wear.

Oil changes: we suggest you use synthetic oil and change it regularly (5000 miles maximum). If you use a mineral oil, change it every 3000 miles. While your supercharger does not use any engine oil for its lubrication, your engine will be working a little harder with

the addition of a supercharger. The synthetic oil provides an extra measure of protection, but is not necessary for safe and reliable operation.

Breaking-in: Your supercharger will work perfectly from the first time you fire it up. However, it does need about 500 miles to fully seat the rotors. Up to that time, you may notice a slight noise coming from the supercharger at idle. This is normal.

10.0 Performance: You will notice that your engine runs stronger during cold days than on very hot ones. This is due to the nature of the internal combustion engine. When the air is cold, the engine receives a denser charge of air, thus more power can be produced. While this is true with any engine, the supercharger amplifies this cold air benefit.

10.1 BELTS

The only item to watch with your supercharger system will be the belt tension for the supercharger drive. If you have a tension gauge for a poly-vee belt, the tension is to be 90 pounds. Without a gauge, look for less than 1/2" deflection on the long run of the belt. If you see a large accumulation of belt dust on your supercharger, it is an indication that your belt is slipping. A slight amount of belt dust is normal.

CHECKING YOUR BELT FOR WEAR: As the belt wears, small cracks will form in each of the ribs on the inside run of the belt. Replace your belt when you can count six cracks within one inch of length (six cracks total from all ribs combined).

10.2 Every six months or so, check your hose clamps for correct tension. The rubber hoses will take a set and the clamps may not be holding as tight. Also check all mounting bolts and nuts, particularly the throttle cable anchor bracket.

10.3 Your air filter is a long-life unit needing service only every 15,000 miles. To clean, order one of the Jackson Racing Air Filter cleaning kits. #901-970. Alternately, you can wash the filter element in soap and water. Use a dish detergent soap such as Dawn, etc. Rinse thoroughly and allow to dry. Wet the filter element with a light application of ATF (automatic transmission fluid).

10.4 At every oil change, lubricate the bypass actuator arm contact point and shaft bushing with light grease to insure long life - these parts are exposed to underhood dirt and grime.

TROUBLESHOOTING

SYMPTOM: Engine cranks but will not start.

PROBABLE CAUSES: Airmass sensor disconnected; Idle air line open; Low battery voltage.

CURE: Double check that the connector to airmass sensor is well connected. Re-check the 3/4" ICS line and the PCV line to see that they are not leaking. Use a known good battery to "jump" the Miata's battery. It is possible to have enough voltage to crank a Miata but not enough to correctly run the engines control computer.

SYMPTOM: No power during boost.

PROBABLE CAUSES: Cross over tube loose.

CURE: Check the cross over tube to see that it is well connected at both ends. Check electrical connections,

SYMPTOM: Unstable Idle.

PROBABLE CAUSE: Idle airscrew set incorrectly; Restrictor left out in step #7.8; air leak in intake track.

CURE: Re-check restrictor. Check idle adjustment procedure in step 8.1 above. Check for air leaks - vacuum at idle should be at least 17.7 in Hg.

11.0 FURTHER MODIFICATIONS

a) When it comes time to put in a new clutch, we recommend the Jackson Racing Stage 1 clutch kit. While your new supercharger and the standard Mazda clutch work well together, it is a good idea to step up to the Jackson Racing unit when you are changing your clutch.

b) A set of Jackson Racing Sport lowering springs will lower the car 25mm and make for better handling

c) A performance muffler will make your supercharged Miata that much faster. Since you are now flowing 300 cubic feet per minute through a muffler designed for 177 cfm, an improvement can be made.

WARRANTY

The supercharger unit itself carries a 2 year or 100,000 mile warranty (for the original purchaser of the kit) against defects in material and workmanship. No other warranties apply. This warranty is void if the subject vehicle is used in any racing activities of any sort.

HELP

If you experience any problems with your kit during installation or operation, contact your retailer or Jackson Racing at 888-888-4079.